

# 10BEVM CAN SEAMER

## SEMI-AUTOMATIC TABLE TOP BEVERAGE CAN SEAMER



### FEATURES:

- Built in UK
- For bars, taprooms, laboratories and product trials
- Can manufacturer approved double seam
- Lifters for standard 330 ml, 440 ml and 500 ml cans
- Lifters for sleek and slim cans available
- Easy changeover for can height and diameter
- Tool kit with micrometer and seam tear down tool

**The 10BEVM is a compact and robust can seamer for closing filled standard, sleek or slim aluminium beer or beverage cans. The single head semi-automatic machine sits comfortably on a table or bench and is ideal for small scale production, laboratory test canning and takeaway crowler cans. It can also be used to replicate a rotary seamer for seam analysis.**

The machine is manufactured fully from food grade 304 and 440C stainless steel, for hygienic beverage canning and the safe use of cleaning agents. Lubrication is with a food grade grease.

The seaming operation is motor driven and manually triggered using a lever. The 10BEVM has the same mechanical components as a high-speed seamer, but in a smaller frame, to ensure the highest commercial quality

seam integrity. Mechanical actuation ensures superior accuracy and consistency of performance in forming the hermetic seal on the can. The seaming rolls have double row angular contact sealed for life bearings and run on vacuum hardened cam profiles, allowing regulation of the number of 1st operation revolutions for optimum double seam formation. The lifter mechanism has an adjustable mechanical spring and is raised against a repeatable dead stop to achieve the correct base pressure of 120 lbf / 550 N.

Tooling changeover for different can heights is quick and easy using the dedicated size change part lifters. Simply pull out a lifter and drop in a replacement. Each lifter has an individual pin height setting to ensure all lifters are set at the correct height. Changeover for different can diameters takes only ten minutes.

# 10BEVM CAN SEAMER

SEMI-AUTOMATIC TABLE TOP BEVERAGE CAN SEAMER

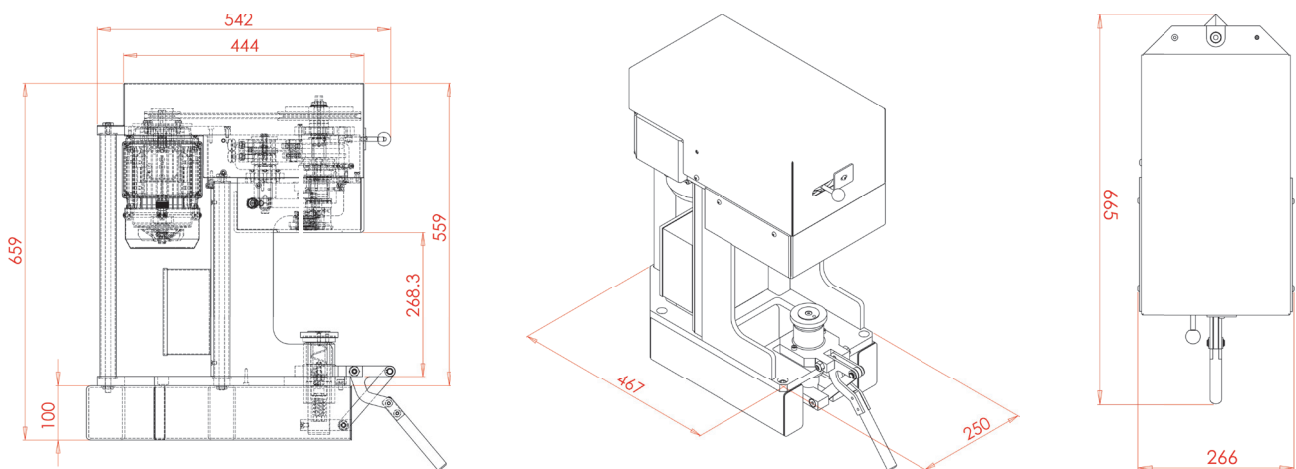

## TECHNICAL DATA

<b>CAN SIZE RANGE</b>	150ML - 500ML
<b>SPEED</b>	UP TO 10 CANS PER MINUTE
<b>AC MOTOR POWER</b>	0.37 KW 240V
<b>NET WEIGHT</b>	85 KG
<b>FOOTPRINT</b>	665 X 266MM